

# ASSEMBLY INSTRUCTIONS

## KITCHEN BASE DRAWER CABINETS

DB12,DB15,DB18  
DB21,DB24

This instruction sheet applies to all DB12,DB15,DB18,DB21,DB24 kitchen base drawer cabinets assembly.

The following parts are included in this carton. Separate and check to see that all parts are accounted for before beginning assembly. If you are missing parts use the form enclosed and fax or mail to us or call us and request that the part(s) be sent to you.

### PARTS LIST

- |  |                     |                    |                |                  |
|--|---------------------|--------------------|----------------|------------------|
| A - Faceframe (1)  | B - Side Panels (2) | C - Back Panel (1) | D - Bottom (1) | E - Toe Kick (1) |
| F - Hardware Bag (1): Corner Braces-4  |                     | Largest Screw - 4  | Medium Screw-8 | Smallest Screw-6 |
| G - Drawer parts (1 set per drawer,depending on model #):  |                     |                    |                |                  |
| a - Front (1), b - Sides w / Slides (1pr), c - Bottom (1), d - Back (1), e - Drawer Slides (1pr), f - Screws (8) |                     |                    |                |                  |

### ASSEMBLY STEPS

**STEP 1:** Remove the Base Drawer unit parts and make sure all are accounted for. Place the Faceframe (A) down on a flat soft working surface to avoid scratching the cabinet.

**STEP 2:** Insert two Side Panels (B) into the grooves of Faceframe (A). Align the plastic half sections of the camlock connectors. Confirm all is flush and lock connectors with a screwdriver by turning the screw located on the camlock connector to the right 180 degrees, reference figure A

**STEP 3:** Insert Bottom (D) into the grooves of Side Panels (B) and Faceframe (A).

**STEP 4:** Position the Back Panel (C) onto Side Panels (B) and work to seat into the Side Panels grooves and over the Bottom (D). Once the Back Panel is aligned and all is flush lock the camlock connectors as above. Position the Toe Kick (E) onto the Side Panels at the front base of the cabinet. Confirm that all is flush and lock the camlock connectors.

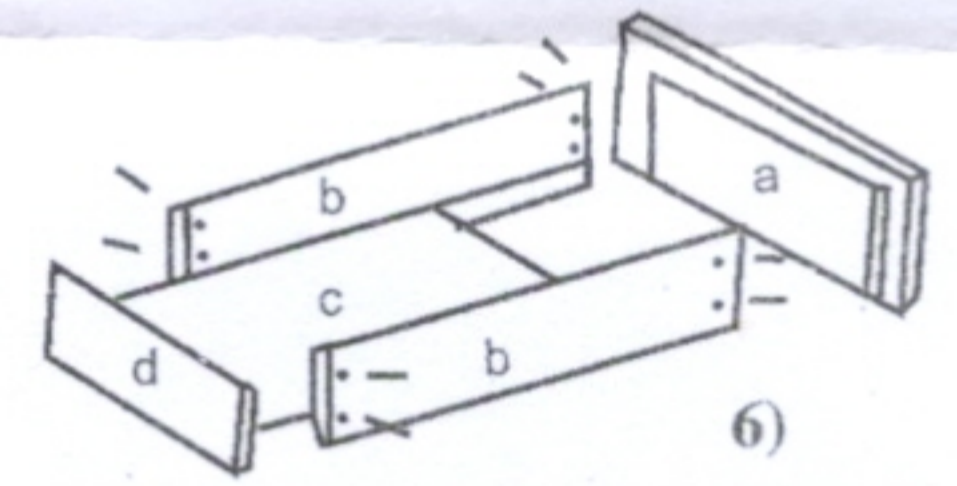
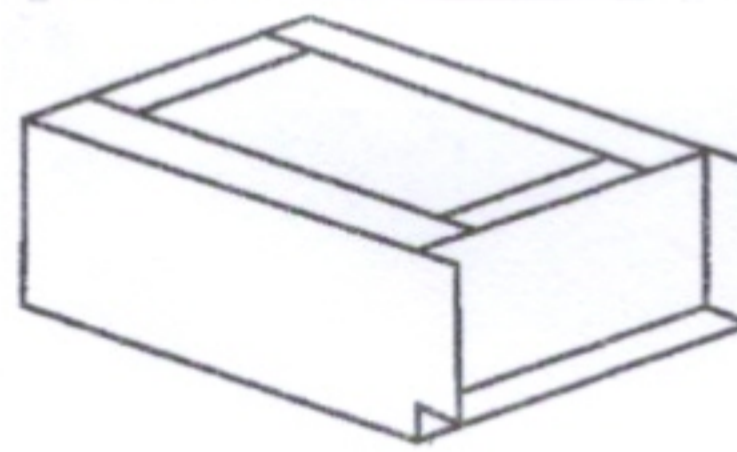
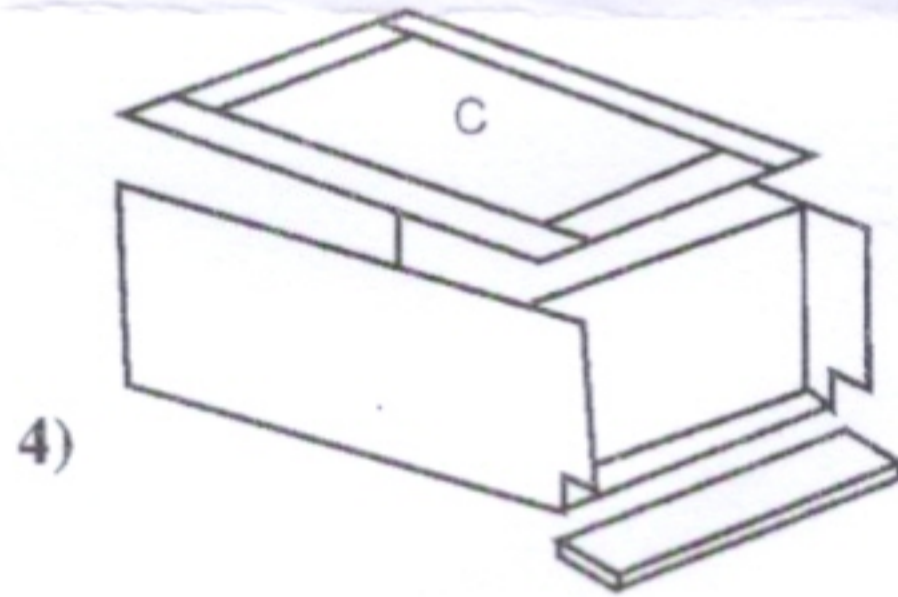
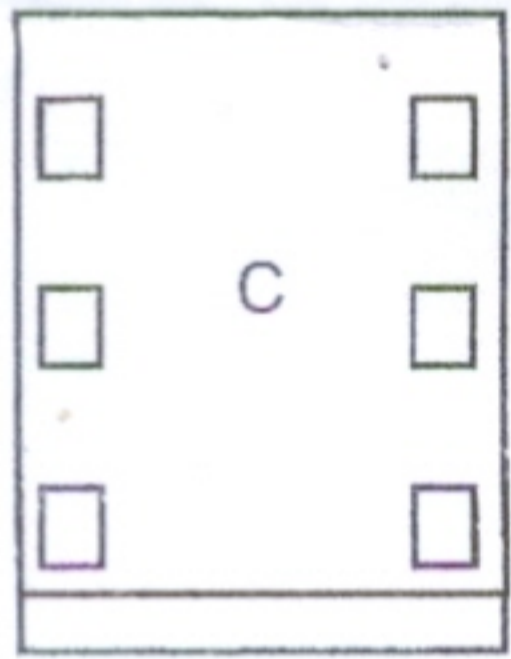
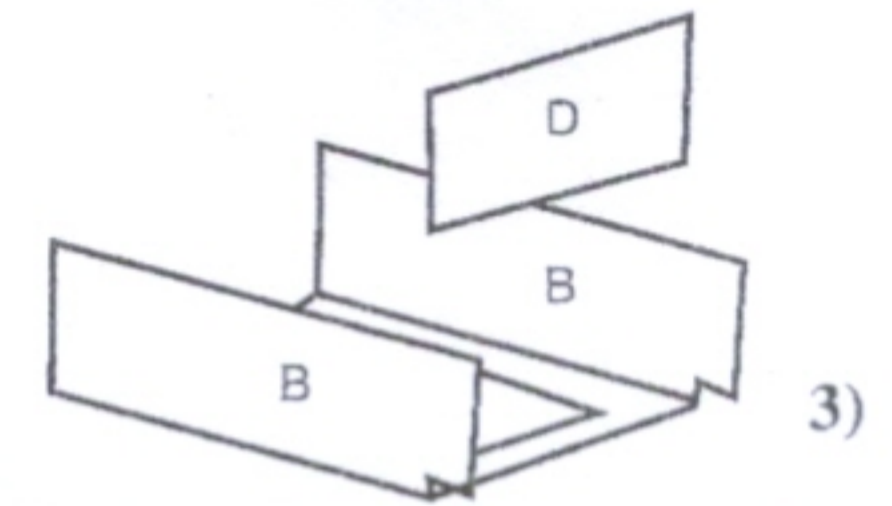
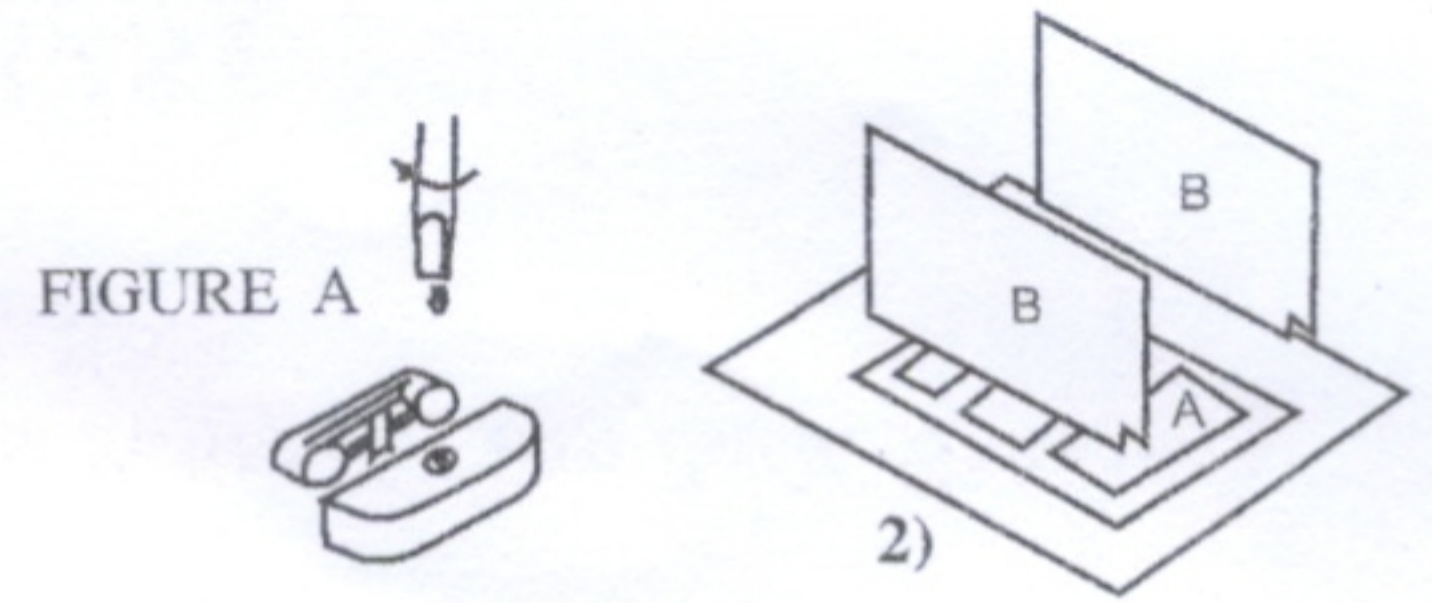
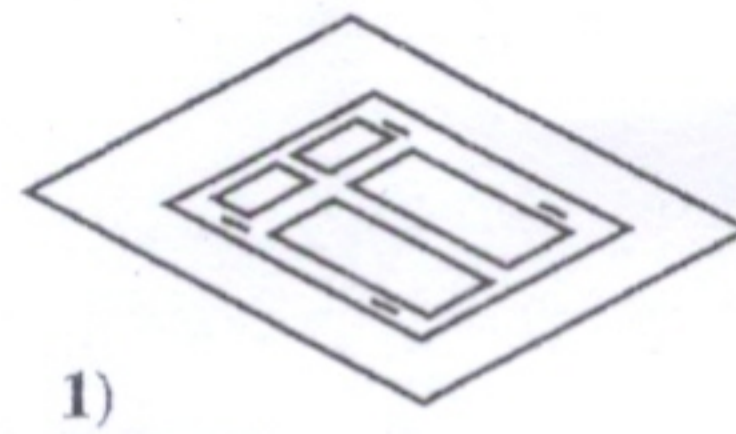

**STEP 5:** Stand the cabinet upright at this time and attach the 4 plastic Corner Braces in each corner of the cabinet using the medium screws. The 4 Largest screws are for use in installation on the countertop to the base cabinet through the 4 Corner Braces.

**STEP 6:** Drawer assembly – Position Sides (b) to Drawer Front Panel (a), align and use two 1.2" countersunk screws (f) to fasten Sides and Drawer Front Panels at each side. Insert and slid Drawer Bottom (c) into the grooves of Drawer Sides (b), then position Drawer Back (d) to the Sides and Bottom, then use two 1.2" countersunk screws at each side to fasten Back and Sides. Repeat these steps to install the other drawer.

**STEP 7:** Slide the Drawer Slide (e) through the drawer opening in Faceframe until the drawer slide is aligned with the Faceframe, and slide the drawer back holder into the preattached drawer boot at the rear of the cabinet. Then locate and fasten into pre-drilled holes in Faceframe with the smallest screws provided. Repeat these steps to install the other drawer slides and insert the assembled drawers if necessary. Check drawer operation and adjust the drawer slide if necessary for best operation.

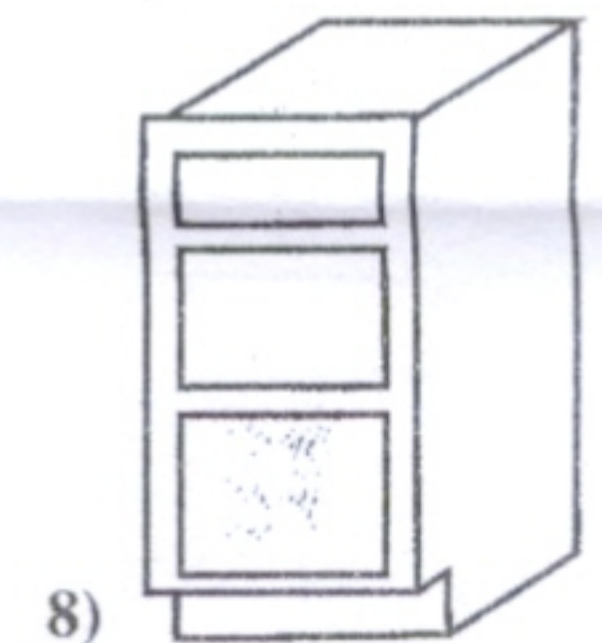
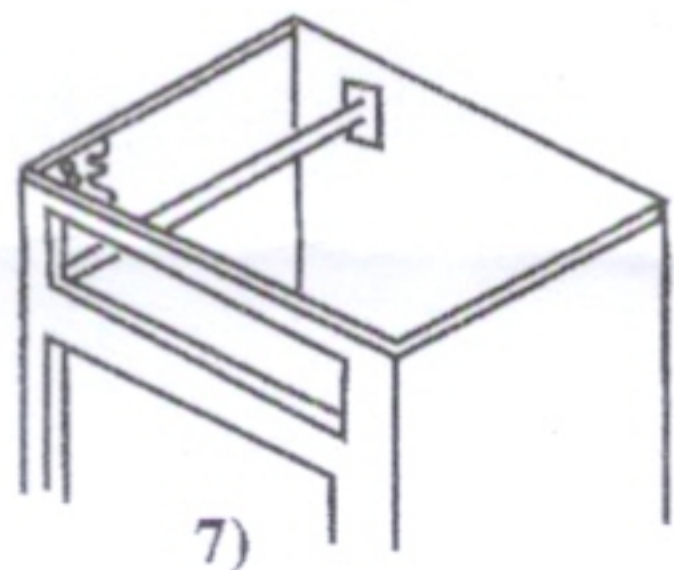
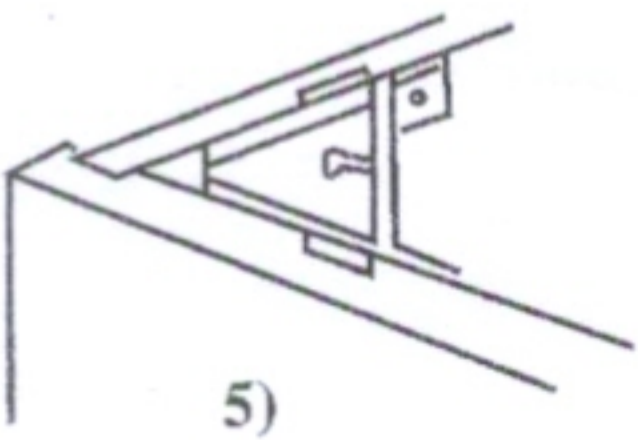

**STEP 8:** Your Base Drawer Cabinet is now complete. For installation, depending upon your existing wall condition (e.g. wood, concrete, tile) consult a professional contractor or building supplier for proper installing method and materials used.